



THEATRE DANCE ASSOCIATION

ORGANIZING WITH A SIDE OF *Fabulous*

**MOVE!**  
NATIONAL DANCE COMPETITION

**NATIONAL DANCE  
COMPETITION©  
2026**  
*A unique experience!*



THEATRE DANCE ASSOCIATION

## INDEX

### Page

3	Dates for entries
7	MOVE! ONLINE
9	Stage Specs
12	Registering Dancers
16	Performance categories
19	Age divisions
21	Time Limits
23	Status and the Point system explained
25	Dance discipline explained
31	Judges
33	Entry fees
38	Dance Categories
45	Regional Awards
48	National wards
51	Special Awards
55	Rules & Regulations

ORGANIZING WITH A SIDE OF *fabulous*

**DATES MOVE!**  
**2026**

## **OPENING DATE**

ALL CITIES, **ALL PROVINCES INCLUDING CAPE TOWN**

Registration, entries & eft payments

**Wednesday 1<sup>st</sup> July 2026**

\*\*\*\*\*

## **CLOSING DATES**

- **GEORGE LIVE EVENT**  
Registration, entries, eft payments submissions  
Wednesday 22 JULY 2026  
**MUSIC UPLOADS (MP3)**  
Friday 24 July 2026
- **KZN LIVE EVENT**  
Registration, entries, eft payments  
Wednesday 22 July 2026  
**MUSIC UPLOADS (MP3)**  
Friday 31 July 2026
- **SOMERSET WEST, LIVE EVENT**  
Registration, entries, eft payments  
Friday 31 July 2026  
**MUSIC UPLOADS (MP3)**  
Friday 14 August 2026
- **ONLINE entries**  
Registration, entries, eft payments submissions  
Friday 31 JULY 2026  
**VIDEO submissions**  
Saturday 15 August 2026
- **PRETORIA LIVE EVENT**  
Registration, entries, eft payments  
Wednesday 12 August 2026  
**MUSIC UPLOADS (MP3)**  
Friday 21 August 2026

- **CAPE TOWN LIVE EVENT**  
Registration, entries, eft payments  
Friday 14 August 2026  
**MUSIC UPLOADS (MP3)**  
Friday 28 August 2026

\*\*\*\*\*

## **REGIONALS START**

- **GEORGE**  
Venue:  
Saturday 8 to Monday 10 August 2026
- **KZN**  
Venue: Westville Boys High School  
DURBAN  
Thursday 13 to Sunday 16 August 2025
- **ONLINE JUDGING**  
**Sunday 16 August to Tuesday 19 August 2026**
- **SOMERSET WEST**  
Venue: De Hoop Primary School  
Friday 28 to Sunday 30 August 2026
- **PRETORIA**  
Venue: Southdowns College  
Saturday 5 to Sunday 6 September 2026
- **CAPE TOWN**  
Venue: Sea Point Civic Centre  
CAPE TOWN  
Monday 14 to Sunday 20 September 2026

\*\*\*\*\*

***MOVE! NATIONALS* (the finals) **LIVE EVENT ONLY****  
**NO ONLINE OPPORTUNITIES AVAILABLE**

Venue: Sea Point Civic Centre.

**CAPE TOWN**

Tuesday 22<sup>nd</sup> September – OUTRIGHT WINNERS Cape Town only

Wednesday 23<sup>rd</sup> – Sunday 27<sup>th</sup> September

all cities/towns/areas

When dancers qualify for NATIONALS, teachers have to  
REGISTER & ENTER those dancers again on the DCG site

**PLUS**

**All MUSIC for NATIONALS must be RELOADED  
onto the DCG site**

**MOVE! ONLINE**

# *MOVE! ...ing online*

**MOVE! REGIONALS ONLINE is run with the same format as MOVE! REGIONALS LIVE**

## **CATEGORIES**

The same as **LIVE REGIONALS SOLOS, DUETS, TRIOS, QUARTETS, GROUPS & PRODUCTIONS**

except

**No IMPROVISATION or BATTLE HIP HOP opportunities ONLINE**

## **JUDGES**

There will be 3 Judges for **REGIONALS** in most major centres and 2 in others. There will be 3 different Judges for **NATIONALS**

The Judges will use the same computerized Dance Competition Programme to mark the **ONLINE** competitors as they use for the **LIVE** Regional competitors.

The Judges marks will be divided by 2/3 to get the overall final mark.

## **HOW TO ENTER ONLINE**

**~ ALL CITIES ~ ALL PROVINCES ~**

There is a video clip available explaining the **"NAVIGATING THE ONLINE PROCESS"**.

This will be sent to teachers on request – please contact the office if you would like a copy

# **STAGE SPECS**

~ **STAGE SPECS** ~

GEORGE  
SOMERSET WEST  
PRETORIA

To Be Confirmed

KZN

**WESTVILLE BOYS HIGH SCHOOL  
STAGE MEASUREMENTS**

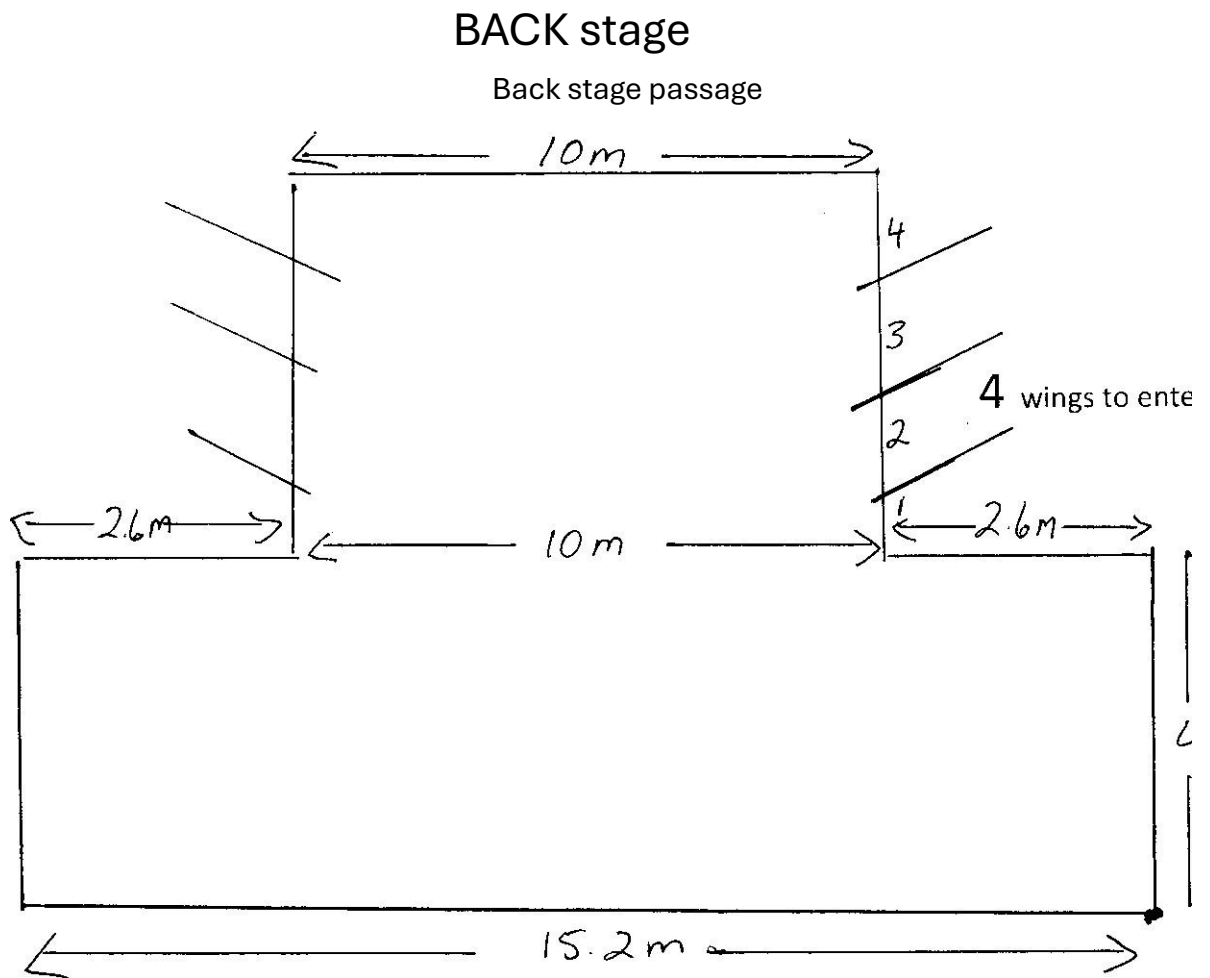

FRONT stage

STAGE N - S = 4.3m (length)

STAGE W - E = 15.2m (width)

## **STAGE SPECS ~ SEA POINT CIVIC CENTRE**

To assist teachers when rehearsing in their studios for **MOVE!** **NATIONAL DANCE COMPETITION** at the Sea Point Civic Centre, please see the stage specs below:

- STAGE LENGTH: 10m
- STAGE WIDTH: 8m
- There will be 7 mats in total, laid from the front to the back of the stage. There will be a CENTRE mat and then 3 on either side of the centre one. The end 2 mats go slightly into the wings
- Each mat is 1.22m wide.
- There are 4 wings on each side of the stage.

# **REGISTERING DANCERS – REGIONALS & NATIONALS**

The information below applies to every teacher entering  
***MOVE!*** whether **ONLINE** or for a **LIVE EVENT**

If not already registered on the portal for a previous TDA competition, copy and paste the following online registration website link into your browser:

<http://thetda.dancecompgenie.com>

- You will then register your studio on the DCG site
- Log in to your newly created site / or log in with previous details.

**Apply to the office for the video clip if not sure of the process**

## **DROP BOX CHOICES ON DCG SITE EXPLAINED:**

**PLEASE DO NOT CONTACT DANCECOMP GENIE DIRECTLY - IGNORE THE CHAT ICON FROM DCG Select An Event:**

- MOVE! REGIONALS ONLINE
- MOVE! REGIONALS – GEORGE LIVE
- MOVE! REGIONALS – SOMERSET WEST LIVE
- MOVE! REGIONALS – PRETORIA LIVE
- MOVE! REGIONALS – DURBAN LIVE
- MOVE! REGIONALS – CAPE TOWN LIVE
- MOVE! NATIONALS

**Entry Type re SOLOS – Select correct option:**

- Studio Solo – can only be selected for MOVE! Regionals
- Competition Solo
- Ballet Repertoire
- Battle
- Improvisation

**Entry Type Re Groups – Select correct option:**

- Groups & Crews
- Any Age Groups
- Adult Groups
- Productions

**Dance Category – Select correct option:**

- Ballet – Demi-Character
- Ballet – Classical

- Stage Branch – Modern
- Stage Branch – Jazz
- Stage Branch – Contemporary
- Stage Branch – Lyrical
- Stage Branch – Characters
- Musical Theatre – Lip Sync
- Musical Theatre – Song & Dance
- Tap
- Hip Hop/Urban
- Acrobatic Dance
- National Dance
- Acrobatic Prop Routine
- Tap – Characters
- Acrobatic Contortion
- Musical Theatre – Tap
- Open

**Dance Categories re Duet/Duo, Trios, Quartets:**

- Ballet – Demi-Character
- Ballet – Classical
- Stage Branch – Modern
- Stage Branch – Jazz
- Stage Branch – Contemporary
- Stage Branch – Lyrical
- Stage Branch – Characters
- Musical Theatre – Lip Sync
- Musical Theatre – Song & Dance
- Tap
- Hip Hop/Urban
- Acrobatic Dance
- National Dance
- Tap – Characters
- Musical Theatre – Tap
- Open

**Dance Categories re Groups:**

- Ballet – Demi-Character
- Ballet – Classical
- Stage Branch – Modern
- Stage Branch – Jazz
- Stage Branch – Contemporary

- Stage Branch – Lyrical
- Stage Branch – Characters
- Hip Hop Large Group (11+ dancers)
- Musical Theatre – Lip Sync
- Musical Theatre – Song & Dance
- Tap
- Acrobatic Dance
- National Dance
- Hip Hop Small Group (5-10 dancers)
- Tap – Characters
- Musical Theatre – Tap
- Open

**Competitive Division**

Select NO STATUS for:

REGIONALS (all)

- **NATIONALS**

Select

Bronze

Silver  Gold

***Notes added on the DCG site must also be sent via email to [fendick@mweb.co.za](mailto:fendick@mweb.co.za)***

**V.I.P. NATIONALS**

Teachers must register all National qualifying dancers on the DCG site ***again***, this time ***adding status*** where applicable.

***MUSIC must be reloaded as well***

# **PERFORMANCE CATEGORIES**

- **STUDIO SOLO** (more than one competitor may do the same dance that the teacher choreographs)

**STUDIO SOLOS ARE NOT ELIGIBLE FOR NATIONALS** – winners will be decided at REGIONALS & will still be awarded bronze, silver or gold status.

MAX TIME 2 mins – can be shorter

- **COMPETITION SOLO STRAIGHTS** (only one competitor may do the same dance)

AT REGIONALS the dancer can perform one or more solos

AT NATIONALS, the dancer may perform ALL THE SOLOS that qualified for NATIONALS. Dancers do not have to choose only their highest scoring solo.

**ELIGIBLE FOR NATIONALS - STATUS AT NATIONALS - Bronze, Silver, Gold**

MAX TIME 3.5 mins – can be shorter

- **COMPETITION SOLO CHARACTERS** (only one competitor may do the same dance)

**ELIGIBLE FOR NATIONALS - STATUS AT NATIONALS - Bronze, Silver, Gold**

MAX TIME 4 mins – can be shorter

- **DUET** (2 competitors)

MAX TIME 4 mins – can be shorter

- **TRIO** (3 competitors)

MAX TIME 4 mins – can be shorter

- **QUARTET** (4 competitors)

MAX TIME 4 mins – can be shorter

**ELIGIBLE FOR NATIONALS– STATUS AT NATIONALS - Bronze, Silver, Gold**

- **BALLET REPERTOIRE**

Dancers may perform more than one Repertoire piece.

10& under & 11 -12

13-15 & 16 & over

- **GROUPS EXCLUDING HIP HOP**

**ELIGIBLE FOR NATIONALS– STATUS AT NATIONALS - Bronze, Silver, Gold**

MAX TIME 5 mins – can be shorter

- **GROUPS HIP HOP ONLY**

**ELIGIBLE FOR NATIONALS– STATUS AT NATIONALS - Bronze, Silver, Gold**

**MAX TIME 5 mins – can be shorter**

SMALL GROUP = 5-10 dancers

BIG GROUP = 11+ dancers

- **ANY AGE GROUPS INCLUDING HIP HOP small & big groups**

**MAX TIME 5 mins – can be shorter**

Must have a combination of a minimum of 3 ages and will compete in the 12 & under or 13 & over age divisions of the competition.

If teachers want their group in an any age section, they must select ANY AGE on the DCG site when entering the group.

**Eligible for NATIONALS. NO STATUS AT NATIONALS**

*At Nationals the same dance disciplines compete against each other  
N.B. The entering teacher must select “ANY AGE GROUP” in the drop-down box on the DCG site when entering the Group*

- **ADULT GROUPS MAX TIME 5 mins – can be shorter**

Competitors must be 30 years or older. If one dancer is in late 20's that will be accepted but the majority of dancers must be 30+

**ELIGIBLE FOR NATIONALS**

**NO STATUS AT NATIONALS**

*At Nationals all dance disciplines compete against each other*

*N.B. The entering teacher must select “ADULT GROUP” in the drop-down box on the DCG site when entering the Group*

- **PRODUCTION**

Must have a minimum of **16+** dancers – MAX TIME LIMIT 6 minutes

- **IMPROVISATION – REGIONALS ONLY**

ALL DANCE DISCIPLINES

Pupils are encouraged to enter this fun section. NO TUITION REQUIRED!

**PROPS PERMITTED** – teachers of the entrants are permitted

backstage, but they may not assist or advise the pupils in any way

The choice and supply of music for all IMPROVISATION sections will be by the Adjudicators. Each competitor will listen to the music twice and on the third time of playing will be expected to perform his / her improvisation.

Candidates do not change status if they receive an HONOURS or a DIPLOMA award for their Improvisation as Winners do not go to Nationals. When the music is played for the first time, ALL competitors must be in the designated areas.

# AGE DIVISIONS

Ages are determined based on the dancer's age on  
January 1<sup>st</sup> of the competition year

## **JUNIOR**

6& under

7-8 years

9-10 years

11-12 years

## **SENIOR**

13 – 14 years

15 – 16 years

17 & over NO max age

### **DETERMINING AGE DIVISION:**

Solos/Duets/Trios/Quartets/Groups/Productions/ Improvisation will compete at the *average age* division determined by averaging the age of all members in the routine. Round-up/down as maths.

*Example:*

- If the average age comes to 12.4, they will compete in the 11–12-year-old age division.
- If the average age comes to 12.5, they will compete in the 13–14-year-old age division.
- 

**NATIONALS – WILL BE DANCED IN THE FOLLOWING 3 AGE CATEGORIES:**

### **12& UNDER – JUNIOR FINALS AGES:**

#### **TINY STARS**

- 6 & under

#### **JUNIORS**

- 7-8 years
- 9-10 years
- 11-12 years

### **13 to 16 yrs – TEEN FINALS AGES:**

#### **TEENS**

- 13 - 14 years
- 15 -16 years

### **17 years + over – SENIOR FINALS AGES**

**PROOF OF AGE:** All performers are required to have proof of ages on hand at every competition. Failure to provide a birth certificate or driver's license if an age division is challenged will result in disqualification of that routine.



# TIME LIMITS

Below are the MAXIMUM times allowed; however, items do not have to be the MAXIMUM time – **they can be shorter**



It is **ESSENTIAL** that teachers enter the **EXACT** and **CORRECT** length of their piece of music on the DCG site as that is how the start and finish times for all the different sections is determined. If your number is 5 minutes and you enter it on the site as 3 minutes, and 20 teachers do this, on that day, we will run 40 minutes late!

**IT IS IMPERATIVE THAT THE EXACT CORRECT TIME IS ENTERED**



Studio Solo:	maximum 2 minutes
Competition Solo STRAIGHT:	maximum 3 ½ minutes
Competition Solo CHARACTER:	maximum 4 minutes
Duet / Trio / Quartet:	maximum 4 minutes
ALL Groups:	maximum 5 minutes
PRODUCTION:	6 minutes

**N.B. RE TIME LIMITS**

If a routine's MUSIC is over the time limit, the DCG site will not accept it

- The length of the music for Improvisation competitors will be:

6-12 yrs	1 minute
13 – 17& over	1 ½ mins

**COMPETITIVE  
DIVISIONS (STATUS)  
&  
POINT SYSTEM**

- When entering **MOVE!** all competitors are dancing to achieve their status for ***that particular year of the competition.***
- When entering each year no one has status.
- In the Regionals there will be **NO COMPARING** of competitors.
- Competitors are all dancing for the highest mark possible and will earn their status with the mark that they receive for their performance that year.

***Status will come into play at NATIONALS.***

To keep every dancer's competition, experience positive and inspirational, we have 3 competitive divisions to aspire to, and ultimately, to level the playing field.

- Each routine that performs will receive a score from each of the 2/3 judges at **REGIONAL** level. Competitors at **REGIONAL** level are competing against criteria related to a point system for status at **NATIONALS**. *They are NOT competing against each other. They are dancing for a mark.*
- Depending on what mark they are awarded at **REGIONALS**, competitors will become one of the following status categories at **NATIONALS** in that particular year:

• BRONZE QUALIFIER • SILVER QUALIFIER • GOLD QUALIFIER  
except for sections that have NO STATUS at **NATIONALS**.

At **NATIONALS**, all competitors in the *same status category*, will compete against each other in a JUNIOR category or a SENIOR category and **will NOW be compared** for the overall awards within their status divisions and age categories

## **POINT SYSTEM out of 100**

64% + below	Honorary mention
65% -74%	Bronze Qualifier
75% -84%	Silver Qualifier
85% -100%	Gold Qualifier

**DANCE  
DISCIPLINES  
EXPLAINED**

## **1. BALLET**

A routine consisting of classical steps & Ballet technique:

*This category covers various dance styles Dancers may enter them all:*

- Classical Ballet, Neo-Classical Ballet, Ballet Avant Garde etc straight **SOLOS** dance in the same section.
- Demi Character **SOLOS** dance in a separate section – dancers receive status at REGIONALS but at NATIONALS they perform with a clean slate - **NO STATUS**
- **In duets, trios, quartets & Groups**, Classical & Characters dance in the SAME section at REGIONALS & NATIONALS with STATUS



### **BALLET REPERTOIRE**

- **Dancers may perform more than one Repertoire piece.**

Ballet Repertoire is a separate section – dancers receive status at REGIONALS but at NATIONALS they perform without

STATUS in 10& under & 11-12 & 13-15 & 16& over

- **12& under** dancers may perform on demi pointe or full pointe – they can still be placed if on demi point - **BUT** if performing EN POINTE at REGIONALS the dancer must then perform EN POINTE at

NATIONALS and vice versa. There can be **NO CHANGES to the Repertoire piece at NATIONAL LEVEL**

- **13& over** dancers must perform EN POINTE.

## **2. NATIONAL DANCE:**

*CATEGORIES:* Irish, Spanish, Greek, African, Tribal, Indian, Belly Dancing, Solo Latin - Any dance style specific to a country and representative of their culture

*Performances are to a significant degree, bound by tradition with strong cultural roots, costuming and music*

**This category will perform in the ballet section of the competition under national dance**

**NATIONAL DANCE** does have STATUS - BRONZE, SILVER, GOLD at Regionals & **NATIONALS** which means that the dancers will not compete against other dancers who got a higher or lower mark at REGIONALS.



**SOLO LATIN DANCE covers:** Cha Cha, Samba, Paso Doble, Rumba and Jive in all sections, in all age categories.

**PLEASE NOTE:** In Solo Latin Duets, trios, quartet, groups, should there be a mix of female and male dancers, no more than 20% of the choreography may be taken in a closed hold with a partner as in couples dancing. This applies to same sex partnering as well.



### **3. STAGE BRANCH**

SOLOS at **REGIONALS**, the dancers compete separately in each of the Style categories and are placed separately, in each of the Style categories. They do not compete against each other. In duets, trios, quartets & Groups, All styles & Characters dance in the SAME section at REGIONALS & NATIONALS with Status.

In **NATIONALS** the different Style categories all compete **in the same category** under the title Stage Branch, irrespective of the style they are performing. **CHARACTER SOLOS** dance separately – NO STATUS Dancers can enter all the style variations for solos

#### **(a) MODERN**

A routine that is performed in this category that is not a LYRICAL, CONTEMPORARY or JAZZ piece.

#### **(b) LYRICAL**

A routine that is performed to the lyrics or mood of the music. Routine should demonstrate balance, extension, isolations, and control utilizing the lyrics or mood of the music. Lyrical dance is a literal representation of the music using a combination of ballet and jazz with a little bit of modern thrown in for good measure. It is usually performed in foot undies or barefoot and tends to be romantic and emotional in approach. Music with vocals and lyrics is preferred but not a rule.

#### **(c) CONTEMPORARY**

Contemporary dance can be almost anything. It can be performed barefoot, en pointe or even in socks on stage. It may or may not be performed to music, sounds or nothing at all except the counts or breath of the dancers. This category will also include the new commercial American contemporary styles, as seen in works by Mia Michaels, Sonya Tayeh and Alvin Ailey. Inventive movements incorporating different styles with classical foundation; Martha Graham, Horton, Cunningham

#### **(d) JAZZ**

Jazz is an energetic dance style, consisting of unique moves depending on specific style and era of jazz. The moves must reflect the jazz dance technique (layouts, jazz pirouettes, fan-kicks, jazz walks, splits, isolation, leaps etc.) which are based on the technique from classical ballet training. As long as the jazz dance vocabulary is used, the music can vary from classic jazz, theatre jazz, Latin jazz to modern day music. Jazz dance encourages individual expression and the development of personal style.

#### **(e) CHARACTERS**

Candidates performing SOLO CHARACTERS compete in their own section under "CHARACTERS" in all the dance styles – in all age categories.

Candidates may lip sync. NO STATUS AT NATIONALS

#### **4. URBAN DANCE STYLE / HIP HOP**

Deriving from Urban Dance culture, the choreography can combine different dance styles of Hip Hop e.g., Oldschool and Newschool. Oldschool includes Pop, Lock, Jazzrock, Hype. Newschool includes: Newstyle, Krumping, Dance Hall. Housedance (footwork, jacking and lofting) is considered as part of this category. Also includes waacking, lyrical, voguing and experimental. Creativity is essential as Hip Hop is a personal expression of emotions or situations and experiences. ***Abusive language / violent expressions forbidden in music and performance.***

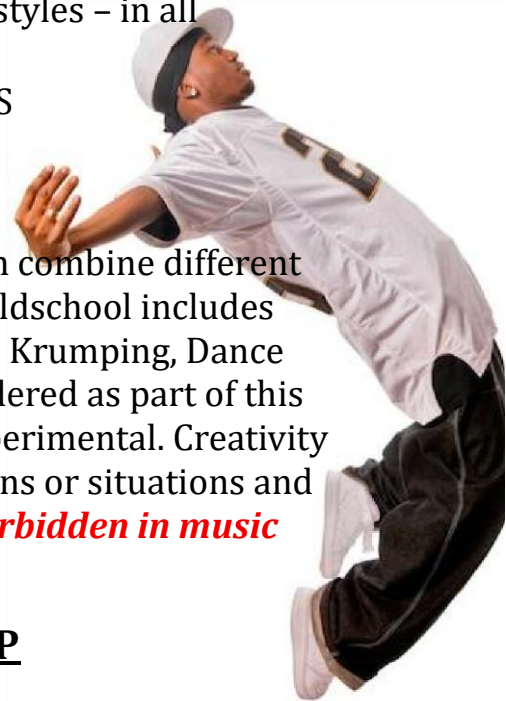

#### **5. BATTLE: URBAN DANCE STYLE /HIP HOP**

**12& under & 13& over.**

**LIVE REGIONALS ONLY.** Not available to ONLINE entrants

**A MINIMUM of 6 12 & under's to run the Junior battle**

**A MINIMUM of 8 13 & overs to run the Senior battle**

**Winners are announced immediately after the section is completed.**

All Style / Freestyle Solo Section

A preliminary round will be held where all dancers, in their age categories perform together - the Judges select who battles who

R750 cash award for SENIOR solo winner

R500 cash award for JUNIOR solo winner

**N.B. 12& UNDER:** Competitors younger than 10 years old will be accepted in this section, but they and their parents must accept that it is a **12& under section.**

## **6. MUSICAL THEATRE**

Musical theatre is a form of performance that should combine singing, or lip syncing, acting and dance. The story and the emotional content of a musical – humour, pathos, love, anger, should be communicated through the choreography. All styles are permitted including both classical and contemporary musicals. Examples: from the 1930 (Singing in the Rain, Oklahoma, Cabaret, and Sweet Charity) up to the present day (Mamma Mia, Producers, Chicago, Wicked, etc.) Storyline, characterization and costume must reflect the chosen musical. Musical character/s must be recognizable. If wearing tap shoes enter the routine into the TAP MUSICAL THEATRE SECTION on the DCG site.

All Musical Theatre pieces, Lip Sync & Song and Dance, compete against each other at **NATIONALS** .

**MUSICAL THEATRE** is divided into 2 sections:

### **(a) Lip Sync**

A routine from a Musical that mimics voices on pre-recorded music and *includes dance*. **NO STATUS**

### **(b) Song and Dance**

A routine from a Musical that *combines dancing and live singing*. This is a vocal/dance section...lead vocals may not be lip synced - may have back up vocal accompaniment. *A handheld, wireless microphone will be provided, or the candidate/s can arrange personal/studio microphones, headsets, etc.* **NO STATUS**

## **7. TAP**

A routine utilizing tap technique performed in tap shoes , creating syncopated rhythms. The routine must contain tap technique and primarily tap work. In **NATIONALS**, **TAP MUSICAL THEATRE PIECES** perform in their own category under **TAP**



## **8. ACROBATIC DANCE**

*This dance discipline offers 3 options. Dancers may enter them all.* At Regionals and Nationals, they remain 3 different sections and do not compete against each other

- **ACROBATIC SOLO**

A routine showing controlled acrobatic moves such as walkovers, front/back limbers, handstands, chest rolls, including, but not limited to headstands, cartwheels, etc. There should be a blend of acrobatics **and dance** together. All acrobatic elements should be linked with dance steps. Acrobatic Dance may contain flexibility moves or contortionist moves AND it must contain dance moves, steps, and choreography.



- **PROP ROUTINE**

The same criteria as for an acrobatic solo but using a prop e.g. handstand canes, box cubes, chair, table etc.

- **CONTORTION**

Contortion is a performance art in which performers called contortionists showcase their skills of extreme back flexibility.

## **9. OPEN DANCE**

Where a piece of choreography has a combination of dance styles, all within one piece of choreography. Emphasis should be placed on originality when combining different dance styles and techniques Where the teacher has an original individual style-teachers are allowed to step outside the prescribed curriculum and devise routines that suit the dancers – NO STATUS



### **BOWS**

No bows permitted after a performance. When the dance is finished the dancer must leave the stage promptly. All entrances and exits onto and off the stage must be swift.

**JUDGES**

**MOVE!** National Dance Competition Regional and National **JUDGES** are skilled in the dance genre that they judge. The Judging panel will comprise combinations of championship calibre competition studio directors, teachers affiliated with major dance studios and currently performing dance professionals. The Judges are all well trained in multiple genres of dance and are sensitive to the various skill levels represented by the dancers' differing ages. This mixture of age, breadth of dance experience and extensive background in performing arts contributes to the diverse range of feedback Judges can offer all our competitors.

Each performance will be evaluated on the following five judging elements:

**1. TECHNIQUE - 45 POINTS TOTAL**

The judges will evaluate the synchronization, timing, mobility & stabilization, skills, execution of the movements performed, the quality of movement throughout the routine, including head, arm, leg & body placement, footwork, standing & air & synchronization of the dancers depending on the technical requirements of routine's discipline. Dancer(s) must maintain control of the speed, direction, momentum, & body placement throughout the routine. Dancers must also demonstrate awareness of spacing between dancers through a range of unique, & challenging formations & interactive partner moves & patterns

**2. STAGE PRESENCE - 30 POINTS TOTAL**

Consists of: **PERSONALITY!** Individual attitude, energy, posture, confidence measured by facial expression, eye contact and body movement; enthusiasm, passion, connection with the audience that generates emotional response (excitement, joy, laughter, sadness) relative to the discipline and story presented will be considered. The routine should leave a memorable and lasting impression

**3. LEVEL OF PERFORMANCE - 10 POINTS TOTAL**

This is measured by the *difficulty of the movements* executed by the dancer/s in a routine. The level of performance should match the technical abilities of the dancers.

**4. CHOREOGRAPHY - ORIGINALITY 10 POINTS TOTAL**

Choreographing and presenting a routine in a unique way - innovative elements as well as creative ways of expressing the choreographer's ideas into the piece - full and creative usage of the stage and the floor, innovative movements, transitions and interpretation of the music. Choreography should be appropriate for the ability and age of the performers.

**5. OVERALL IMPRESSION /APPEARANCE - 5 POINTS TOTAL**

Clothing and accessories worn should represent and reflect the routine. Whilst an innovative and creative selection of costumes is encouraged, it is not a criterion.

***All judges' decisions are FINAL.***

**ENTRY FEES &  
REGISTRATION**

**REGIONALS &  
NATIONALS**

The TDA have purchased, from an International Company, the Licence and Services Agreement for the use of their International computerised Dance Competition Programme. This Licence allows the TDA to progress MOVE! to international standards by keeping abreast of 21<sup>st</sup> century technology using these on-line facilities and the computer hardware to run the competition. The Licensee is granted access according to the terms and conditions of the purchase which requires **a registration fee**, to be paid by each dancer, for his/her usage, scheduling, tabulation, and feedback afforded by the international programme. **PLEASE NOTE:** The REGISTRATION FEE is separate from the ENTRY FEE

## **REGIONALS - REGISTRATION FEE** **TEACHERS ~ TDA MEMBERS**

*NO TEACHER/studio registration fee if teacher is a TDA member.  
The TDA sponsors the teacher's registration fee as a "members perk"*

Teacher/studio owner **PLUS ONE HELPER /ASSISTANT** will be allowed free entry backstage plus unlimited access backstage, and on stage, including free entry to the auditorium when pupils are performing.

If the studio requires any more teachers/assistants/helpers than the ONE TEACHER & ONE HELPER THAT DO NOT PAY, they will be required to pay the backstage access fee of R200 if they wish to have the same benefits, EXCLUDING free entry to watch the dancers perform on the day

## **REGIONALS - REGISTRATION FEE** **TEACHERS ~NON TDA MEMBERS**

R300 teacher/registration fee per **STUDIO**. This fee will allow free entry to the studio owner. Any more teachers from the same studio will be required to pay the access fee of R200 if they wish to have the reg fee benefits, being unlimited access backstage and on stage excluding free entry into the auditorium when his/her pupils are performing.

## **REGIONALS - REGISTRATION FEE** **DANCERS**

R300 registration fee per dancer – per studio

For this fee, each dancer will receive a percentage mark, status, an overall placing, 2/3 reports, a certificate, & if the dancer qualifies for **NATIONALS**, he/she will also receive a **"Qualified to Move!"** award  
...excluding BATTLES & IMPROVISATION

**PLUS A ONCE-OFF fee of R100 for RANOS Productions** to film *every item* that the dancer performs from the SAME studio at MOVE! REGIONALS. This fee will provide the dancer with a video clip of *every item* he/she performs in the competition at Regionals and in all dance disciplines that they learn in the **SAME** studio if the dancer enters more than one discipline. No matter how many items and dance disciplines the dancer enters at REGIONALS, in the **SAME** studio, he/she will receive their video clips for just R100.

Dancers learning more than one dance discipline in the **SAME STUDIO** pay ONE ONLY Registration fee & ONE ONLY video fee of R100 (for a video clip of every dance the dancer performs at Regionals)

Dancers learning more than one dance discipline in **MORE THAN ONE DANCE STUDIO** pay a Registration & VIDEO fee **PER STUDIO ENTERING THEM**

For this fee, each dancer will receive a percentage mark, status, overall placing, 2/3 reports, a certificate, & if the dancer qualifies for NATIONALS, he/she will also receive a **“Qualified to Move!”** award  
...excluding BATTLES & IMPROVISATION

## **ENTRY FEES REGIONALS**

An entry fee, per item entered, is charged for **REGIONALS ONLY**.

No entry fees are charged for NATIONALS.

- R300 per dancer, per solo in REPERTOIRE CATEGORY
- R300 per dancer, per solo in all SOLO CATEGORIES
- R250 per dancer, per DUET / TRIO / QUARTET
- R200 per dancer IMPROVISATION
- R150 per dancer, per GROUP, PRODUCTION
- R150 per dancer, per BATTLE entry

## **NATIONALS – FEES – DANCERS & TEACHERS**

- **NO ENTRY FEES** are charged for DANCERS who perform at NATIONALS.
- There is only a once-off Registration fee of R300 per DANCER, **irrespective of how many items he/she performs at NATIONALS.**
- **NO registration fee charged for TEACHERS for NATIONALS,** irrespective of whether the teacher is a TDA member or not.
- Assistants/helpers who paid registration fee for REGIONALS do NOT pay again to assist backstage for NATIONALS.
- **NEW** assistants /teachers brought in for NATIONALS must pay the REGIONAL assistant/helper fee of R200



## REFUND POLICY

- All competition entry & registration fees are non-refundable. No refunds will be issued under any circumstances.



- You are not a registered contestant unless your payments have been received. All entries **MUST** be **PAID IN FULL** before they will be processed.
- All entries must include the correct names and DOB of all contestants.
- The name of a routine may not be the name of the Dance Studio.
- After entries have been loaded, teachers must check their entries on their DCG site **DASHBOARD**.
- It is imperative that teachers check this information including birth date and age division and reply **IMMEDIATELY** with any corrections. **NO CHANGES WILL BE PERMITTED LESS THAN 14 DAYS PRIOR TO THE COMPETITION OR AT THE COMPETITION.**

Teachers to check that they have included their add-ons (extra teachers or helpers)

Payment at this stage must be made in full and proof of payment must be forwarded to the office

- Where there is no teacher, independent entries are welcome. **A STUDIO REGISTRATION** fee will still apply
- Only religious holidays will be considered for impossible dates in the HEATS and such special requests **MUST** be listed when entering the pupil/s on the DCG site. This however **does not apply on the days of NATIONALS where NO SPECIAL REQUESTS WILL BE ACCEPTED**

# PAYMENT

**REGIONAL** entries are done online prior to the competition date.

**PAYMENT IS BY EFT or CASH paid in at the OFFICE.  
NO CASH DEPOSITS TO BE MADE INTO THE ACCOUNT**

## **BANKING DETAILS**

**MOVE! NATIONAL DANCE**

**COMPETITION NEDBANK**

**CONSTANTIA VILLAGE**

Account number:

1184900523

Branch code: 101109

**V.I.P.** Use **teacher's name as reference** when making payment

Email PROOF OF PAYMENT TO:

**theatredanceassociation@gmail.com**

## **TEACHERS & PARENTS ARE REMINDED OF THE FOLLOWING:**

There is a:

- SPECTATOR FEE FOR AUDIENCE MEMBERS at REGIONALS & NATIONALS
- SPECTATOR FEE FOR DANCERS
- DANCERS performing in a session at REGIONALS, do not pay to watch **THAT session, on THAT day**. However, if they watch any OTHER sessions on the same day that they did not compete in, they will be required to pay an entrance fee.
- **NATIONALS:**  
**ALL DANCERS PAY TO WATCH NATIONALS even if they are performing. This is a reduced fee**

# **DANCE CATEGORIES**

# STUDIO SOLO

**NOT ELIGIBLE FOR NATIONALS  
WINNERS DECIDED AT REGIONALS**

**STATUS CATEGORIES:** awarded at REGIONALS ONLY

1. Honorary Mention	64% & below
2. Bronze Status	65 -74%
3. Silver Status	75 -84%
4. Gold Status	85 -100%

## **AGE CATEGORIES**

- 6 & under
- 7-8 years
- 9-10 years
- 11-12 years
- 13-14 years
- 15-16 years
- 17 & over

**ALL DANCE DISCIPLINES**



# COMPETITION SOLOS

Only ONE competitor may do the dance  
This category is intended for the more accomplished dancer

**ELIGIBLE FOR NATIONALS**

65% & above

## **STATUS CATEGORIES**    **BRONZE, SILVER, GOLD**

- |                     |             |
|---------------------|-------------|
| 1. Honorary Mention | 64% & below |
| 2. Bronze Qualifier | 65% -74%    |
| 3. Silver Qualifier | 75% - 84%   |
| 4. Gold Qualifier   | 85% -100%   |

## **AGE DIVISIONS**

- 6 & under
- 7-8 years
- 9-10 years
- 11-12 years
- 13-14 years
- 15-16 years
- 17 & over

## **ALL DANCE DISCIPLINES**



# GROUPS

## ALL DANCE DISCIPLINES ELIGIBLE FOR NATIONALS

65 % & above

### STATUS CATEGORIES BRONZE, SILVER, GOLD

1. Honorary Mention 64% & below
2. Bronze Qualifier 65% -74%
3. Silver Qualifier 75% - 84%
4. Gold Qualifier 85% -100%

### AGE DIVISIONS

- 6 & under
- 7-8 years
- 9-10 years
- 11-12 years
- 13-14 years
- 15-16 years
- 17 & over
- Adults (30+ NO STATUS)



STATUS AT NATIONALS (except Adults 30+)

BRONZE, SILVER, GOLD

# ANY AGE GROUPS

## ELIGIBLE FOR NATIONALS

65% & above

*Must have a minimum of 3 different age groups*

- |                     |             |
|---------------------|-------------|
| 1. Honorary Mention | 64% & below |
| 2. Bronze Qualifier | 65% - 74%   |
| 3. Silver Qualifier | 75% - 84%   |
| 4. Gold Qualifier   | 85% - 100%  |

## NO STATUS AT NATIONALS

### AGE DIVISIONS ALL DANCE DISCIPLINES

- Junior (12 & under)
- Senior (13 & over)



# PRODUCTIONS

ELIGIBLE FOR NATIONALS  
65% & above  
NO STATUS AT NATIONALS

## AGE DIVISIONS ALL DANCE DISCIPLINES

- Junior (12 & under)
- Senior (13 & over)

ALL Productions, in all dance disciplines, compete against each other, at the SAME time in the category called **PRODUCTIONS** in the STAGE BRANCH section of MOVE!

At Nationals, the Production obtaining the highest mark, irrespective of Dance Discipline, wins the THEATRE DANCE Trophy. 2nd & 3rd placings will also be awarded.

A synopsis of the story line (if any) must be handed to the announcer before the section starts. Productions have no age category. They are either 12& u (JUNIOR PRODUCTION) or 13& over (SENIOR PRODUCTIONS)



Dancers  
don't need  
wings to fly!



# IMPROVISATION

**NOT ELIGIBLE FOR NATIONALS  
WINNERS DECIDED AT REGIONALS**

**STATUS CATEGORIES:** awarded at REGIONALS ONLY

1. Honorary Mention	64% & below
2. Bronze Status	65 -74%
3. Silver Status	75 -84%
4. Gold Status	85 -100%

## **AGE CATEGORIES**

- 6 & under
- 7-8 years
- 9-10 years
- 11-12 years
- 13-14 years
- 15-16 years
- 17 & over



## **ALL DANCE DISCIPLINES**

Awards for MOST OUTSTANDING IMPROVISATION 12 & under / 13 & over gaining the highest marks





# Regional Awards

All competitors will receive certificates & 2 / 3 report sheets in:

- each category (Solos, duets, trios, quartets, groups, Any age groups, Productions and Improvisation)
- each age division
- each status category: Honorary Mention, Bronze Qualifier, Silver Qualifier, Gold Qualifier
- all dance disciplines

Dancers who qualify for **NATIONALS** receive a **NATIONAL'S QUALIFIER** award

### **TOP 3 HONORARY MENTION DANCERS (STUDIO SOLO AWARDS)**

with the highest scores – in EACH dance discipline and ALL age divisions receive an award

### **TOP 3 BRONZE, SILVER, GOLD DANCERS (STUDIO SOLO AWARDS)**

with the highest scores – in EACH dance discipline, in ALL status categories and in ALL age divisions, receive an award

### **TOP 3 BRONZE, SILVER, GOLD DANCERS (COMPETITION SOLO AWARDS)**

with the highest scores – in EACH dance discipline, **plus** Repertoire, in **ALL status categories** and in ALL age divisions, receive an award

### **TOP 3 BRONZE, SILVER, GOLD DUETS, TRIOS & QUARTETS**

with the highest scores in each category – in EACH Dance Discipline, ALL status categories and in each Age Division, receive an award

### **TOP 3 BRONZE, SILVER, GOLD GROUPS**

AWARDS to the TEACHERS of the Groups placed 1<sup>st</sup>, 2<sup>nd</sup> & 3<sup>rd</sup> in each dance discipline, in each status category and each age division. All dancers in the Groups placed 1<sup>st</sup> in each dance discipline, in each status category and each age division also receive an award.

### **TOP 3 ANY AGE & 30 & OVER AGE GROUPS**

AWARDS to the TEACHERS of the Groups placed 1<sup>st</sup>, 2<sup>nd</sup> & 3<sup>rd</sup> in each dance discipline, in each status category and each age division.

All dancers in the Groups placed 1<sup>st</sup> in each dance discipline, in each status category and each age division also receive an award.

### **TOP 3 IMPROVISATION – HIGHEST MARKS**

#### **AWARDED**

AWARDS to dancers placed 1<sup>st</sup>, 2<sup>nd</sup> & 3<sup>rd</sup> gaining the highest marks, in each dance discipline, in each age division.

### **TOP 3 PRODUCTIONS**

AWARDS to the TEACHERS of the Productions placed 1<sup>st</sup>, 2<sup>nd</sup> & 3<sup>rd</sup> overall, any dance discipline, and in both age division 12 & / 13 & over.

All dancers in the Production placed 1<sup>st</sup> in any dance discipline, in each status category and each age division also receive an award.

The background features a dark field with numerous vertical purple and blue light streaks of varying lengths and thicknesses. Interspersed among these streaks are several bright, multi-pointed starburst or lens flare effects, primarily in shades of yellow and white. The overall effect is one of dynamic energy and celebration.

# National Awards

**STATUS CATEGORIES  
BRONZE, SILVER, GOLD**

• **BEST COMPETITION SOLO**

Awards to each dancer placed 1<sup>st</sup>, 2<sup>nd</sup>, 3<sup>rd</sup> in each dance discipline, in each age division  
6 & under through to 17 & over and in each status category,  
BRONZE, SILVER & GOLD

• **BEST DUET**

Awards to dancers placed 1<sup>st</sup>, 2<sup>nd</sup>, 3<sup>rd</sup> in each dance discipline, in age division  
6 & under through to 17 & over and in each status category,  
BRONZE, SILVER & GOLD

• **BEST TRIO**

Awards to dancers placed 1<sup>st</sup>, 2<sup>nd</sup>, 3<sup>rd</sup> in each dance discipline, in age division  
6 & under through to 17 & over and in each status category,  
BRONZE, SILVER & GOLD

• **BEST QUARTET**

Awards to dancers placed 1<sup>st</sup>, 2<sup>nd</sup>, 3<sup>rd</sup> in each dance discipline, in age division  
6 & under through to 17 & over and in each status category,  
BRONZE, SILVER & GOLD

• **BEST REPERTOIRE ENTRANT NO STATUS**

Winner **10& under**

Winner **11 to 12 years**

Both winners placed 1<sup>st</sup> get R700 cash - Dancers placed 2<sup>nd</sup>, 3<sup>rd</sup> get awards

Winner **13 to 15 years**

Winner **16 & over**

Both winners placed 1<sup>st</sup> get R1000 cash - Dancers placed 2<sup>nd</sup>, 3<sup>rd</sup> get awards

• **BEST GROUPS**

In each dance discipline, in each age CATEGORY and in each status category, BRONZE, SILVER & GOLD

TROPHY to the Group placed 1<sup>st</sup>

AWARDS to the Groups placed 2<sup>nd</sup>, 3<sup>rd</sup>

**• BEST ANY AGE GROUPS**

**NO STATUS**

In ALL DANCE DISCIPLINES 12&U under /13 & over

TROPHY to the Group placed 1<sup>st</sup>

AWARDS to the Groups placed 2<sup>nd</sup>, 3<sup>rd</sup>

**• BEST 30+ GROUPS**

**NO STATUS**

In ALL DANCE DISCIPLINES TROPHY to the Group placed 1<sup>st</sup>

AWARDS to the Groups placed 2<sup>nd</sup>, 3<sup>rd</sup>

**• BEST PRODUCTION**

**NO STATUS**

In ALL DANCE DISCIPLINES - TROPHY to the Production placed 1<sup>st</sup>

AWARDS to the Productions placed 2<sup>nd</sup>, 3<sup>rd</sup>

# NATIONALS

## SPECIAL AWARDS

**JUDGES CHOICE AWARDS: 12 & u / 13 & over**  
**~ ANY DANCE DISCIPLINE ~ ANY CATEGORY ~**

**ANNOUNCED AT FINALS**

12 & u & 13 & over

These distinguished awards are presented to individuals who display exceptional dance showmanship, chosen by the Judges at NATIONALS.

- “The X factor” award
- “Wild About You” award
- “Star Potential” award
- “Dynamic Personality” award
- Most outstanding SOLO
- Most outstanding MALE dancer
- Ballet Groups Veronique Vleghert
- Most Eye-Catching entrant
- TDA Fabulous! YOU stood out!



**Decided by the highest marks awarded at REGIONALS**

- Most outstanding TAP dancer
- Most outstanding BALLET dancer
- Most outstanding HIP HOP dancer
- Most outstanding MODERN dancer
- Most outstanding NATIONAL dancer **covers** Irish, Belly Dancing, Spanish, Solo Latin, Greek, African, Tribal, Indian, etc
- Most outstanding ACROBATIC dancer
- Most outstanding MUSICAL THEATRE performer



# TEACHER AWARDS

## 12 & u & 13 & over



Email: [theatredanceassociation@gmail.com](mailto:theatredanceassociation@gmail.com)

Cell: 082 063 9996

*This brochure and its contents are protected by copyright laws.  
It is not available to reproduce, replicate, duplicate, take from, re-use, forward to anyone or plagiarize in any manner whatsoever.*

***MOVE! NATIONAL DANCE COMPETITION© has the same copyright protection***

*Right of admission reserved*

**JUNIOR FINALS** opens NATIONALS (Could run for 2 days?)  
**TEEN/SENIOR FINALS** will follow (could run for 2 days?)



### **The announcement of special awards: DANCERS OF THE YEAR AWARDS ANY DANCE DISCIPLINE**

**CASH AWARDS** - Awarded in 4 age categories  
Winners must have competed in a minimum of 3  
different categories and must include a  
Solo (eg: Solo, Duet, Group)

- **Mini** – Soloists aged 8 & under **R500**
- **Junior** – Soloists aged 9 – 12 **R750**
- **Teen** – Soloists aged 13 – 16 **R1000**
- **Senior** – Soloists aged 17 & over **R1500**



# **CHOREOGRAPHER OF THE YEAR AWARDS**

**ANY GENRE**

12& under ~ 13& over Awarded for  
GROUP, ANY AGE GROUP, PRODUCTION CHOREOGRAPHY

**R1000 cash award to the 12 & under Choreographer**

**R1500 cash award to the 13 & over Choreographer**

with the most nominations from the panel of judges. These esteemed awards will be presented to the 2 choreographers whom the Judges decide displayed exceptional choreography.

**PLUS, A FLOATING TROPHY TO EACH CHOREOGRAPHER**

**THE GRACE & BUDDY WOODBORNE TROPHY**

*In memory of an exceptional woman: Grace Woodborne*

*JUNIOR WINNER*

**TDA GRAND TROPHY**

*SENIOR WINNER*

**OPERATION SMILE – MOVES CHOICE OF CHARITY 2025**

Charity cheque handover to OPERATION SMILE

**THE 2026 SA DISNEY TEAM**

The announcement of Team SA 2026 and the awarding of TEAM SA certificates will be done separately, the night AFTER MOVE! finishes



***MOVE! NATIONAL DANCE  
COMPETITION©***



**Please ensure that the RULES governing MOVE! NATIONAL DANCE  
COMPETITION have been carefully read and fully understood.**



Studios and teachers who register to enter **MOVE! NATIONAL DANCE COMPETITION** will be deemed as accepting of, and adhering to, the **CODE OF ETHICS**.

- 1 At all times members will be expected to avoid any criticism of the methods and manner adhered to.
- 2 Loyalty to our chosen profession is paramount and at no time should a member cause any publicity that could be deemed to lower the dignity and standing of our profession or Association. No damage to the individual reputation of any colleague will be accepted or tolerated.
- 3 Any breach of professional etiquette will render the teacher / studio liable for suspension and / or expulsion from **MOVE!**

The THEATRE DANCE ASSOCIATION Board reserves the right to determine what constitutes a “breach of professional etiquette”.

- 4 Any complaints of professional misconduct must be submitted to the THEATRE DANCE ASSOCIATION **MOVE!** panel for consideration.
- 5 The THEATRE DANCE ASSOCIATION presents **MOVE! NATIONAL DANCE COMPETITION** for teachers and pupils to work competitively in a respectful and dignified arena. The teachers and pupils will always be treated with respect. Teachers, pupils, and their parents must adopt the same level of courtesy and behaviour.

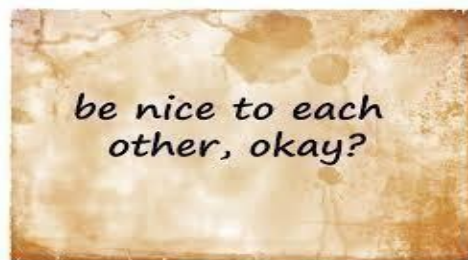

# Obey the Rules

## ON STAGE SECURITY CONTROL

**NO PARENTS WILL BE PERMITTED BACKSTAGE AT ANY TIME, FOR WHAT EVER REASON, DURING THE FULL RUN OF THE COMPETITION UNLESS THEY ARE REGISTERED HELPERS AND HAVE PAID THE REGISTRATION FEE  
ONLY REGISTERED "PERSONS" HAVE UNRESTRICTED ACCESS ONSTAGE**

- A STUDIO Registration fee of R300 is required for every NON TDA teacher entering and that fee will allow the **studio owner/s** unlimited access backstage and on stage.
- **Helpers/Assistants** pay R200 for backstage access and must be registered on the DCG site at the time of a studio entering. Where it says "**TEACHER**" on the DCG site, if a studio owner has 2 helpers, the Studio owner will register "**3 TEACHERS**" 1@ R300 and 2 @ R200
- Curtains will remain open throughout the Competition.
- Candidates must NOT bring valuables to the venue. If they do, then these valuables must be given to family members when they go backstage to perform or to their teacher for safe keeping. Valuables left in the dressing rooms are done so at the owner's risk.
- If a teacher is, for any reason, unable to be present for the duration of the competition, he / she must ensure that a responsible person has been **REGISTERED** to act on his / her behalf. The Organisers must be advised of this individual's name prior to the teacher leaving the venue and they will be required to register and wear a name tag to gain access to the stage.
- Competitors must be ready to perform **30 minutes** prior to the commencement of their section. Failure to be ready if the event is running early shall result in the competitor/s being deemed noncompetitive



*TEACHERS must advise parents of this requirement.*  
*Parents must know that the competition could run as early as 30 minutes, so that they arrive in good time to watch their children perform.*

- Competitors will be called by a runner prior to their section commencing. If the competitors are not ready when called or when the section starts, the competitors will forgo their chance to dance. Teachers are responsible for ensuring that their dancers are waiting in the passageway leading to the stairs onto the stage, ready to be called for their performance.
- Dance titles will be announced. If a synopsis is to be read out, it must be as brief and as clear as possible. A **TYPED** copy of the synopsis must be given to the announcer in good time and **prior to** the commencement of the session.

### **LATE ENTRIES**

These will be accepted at a 50% penalty fee

### **SUBSTITUTE DANCERS**

If for any reason a dancer has to be substituted at REGIONALS OR NATIONALS, if not already entered, that replacement dancer must pay the mandatory REGISTRATION FEE for **REGIONALS & NATIONALS**.

*Certificate will be awarded to the replacement dancer but because all certificates are prepared through the DCG site upon REGISTRATION, the onus will lie with the teachers to notify the office AFTER THE COMPETITION of who their substitutes were so that certificates can be prepared and emailed to the teacher.*

### **CHANGING CHOREOGRAPHY FOR NATIONALS**

This is **NOT PERMITTED**. The dancer/s went through to NATIONALS on their routine in REGIONALS and that **EXACT** routine must be re-danced at NATIONALS



## **INCORRECT SPELLING OF NAMES**

Unless this is a TDA mistake, certificates with names incorrectly spelt by the entering teacher on the DCG site will be replaced at a fee of R30 per certificate. **The certificate/s will be prepared and sent via email after the competition ends.**

**ONLY the first and last name of the dancer must be entered on the DCG site – no middle name/s.**

- **CHANGING IN FOYER TOILETS**

Dancers are strictly forbidden to use the Foyer toilets to change into or out of their costumes.

- **MOVE! INFORMATION BROCHURE**

It is IMPERATIVE that entering teachers **READ the Brochure THOROUGHLY** and constantly refer to it to alleviate all the queries that the office receive when the answers to those queries are in the brochure.

- **OFFICE HOURS**

The Organisers may be contacted **MONDAY to SATURDAY 9:30am to 9:00pm.** WhatsApp messages, phone calls and voice notes will not be answered on a **SUNDAY**

- **PROPS**

Please be as swift as possible when moving props on and off the stage. It is preferred that dancers are responsible for putting their props on stage – always impressive to see this happening - and taking them off. If assistance is needed, the TDA stage crew will assist. After the performance, all props must be removed from the stage area, unless the number is going through to compete at NATIONALS

- **CAMERAS BACKSTAGE**

Teachers photographing their pupils backstage, while dancing, must not use a flash.

- **LOST PROPERTY**

It is not the responsibility of the organisers to collect lost property left at the venue during or after the run of **MOVE! NATIONAL DANCE COMPETITION**. Teachers, parents, and dancers are requested to please not contact the organisers regarding anything left at the venue. It is suggested that they phone the venue direct.

## **INDEMNITY**

**MOVE! NATIONAL DANCE COMPETITION** and its staff and entering teachers will not be held responsible for any injury, loss or damage incurred by anyone during the run of the competition. Studios, teachers, dancers & parents who register to enter **MOVE! NATIONAL DANCE COMPETITION** will be deemed as accepting of this.

## **AMENDMENTS**

This syllabus contains the planning of **MOVE! NATIONAL DANCE COMPETITION** for the year 2026. Where required, by circumstances, the TDA reserve the right to make amendments. Such amendments, as well as any further arrangements of concern, will be notified to all parties promptly.



***It is suggested that teachers copy this THEATRE RULES page and forward it to their parents.***

Please ensure that these THEATRE RULES are carefully read and fully understood before entering the auditorium.

**TEACHERS** – the onus is upon you to ensure that *your parents are aware of them.* If they are not told, they will not know. This then causes unnecessary problems on the day, but the parents are not to blame – the teachers are! Proud parents will arrive with video equipment, cameras etc, understandably so, ***IF THEY DO NOT KNOW ITS NOT ALLOWED.***

### **CAMERAS / VIDEOS**

**NO VIDEO or PHOTOGRAPHIC EQUIPMENT will be ALLOWED IN THE AUDITORIUM for the full run of the event.**

Anyone who chooses to ignore this rule and who does video or take photographs of the candidates - and that includes on a cell phone - will be asked to leave the auditorium immediately and will not be permitted to return.

A professional video will be on sale and copies can be ordered in the foyer.

### **CELL PHONES**

The organisers request that cell phones be turned off when in the auditorium and not used, out of respect for the dancer/s performing.

### **ENTERING THE AUDITORIUM**

Members of the public are requested not to enter or leave the auditorium during a performance, out of respect for the dancer/s performing.

**RIGHT OF ADMISSION RESERVED**

**This rule applies to receiving entries and spectator admissions**



The THEATRE DANCE ASSOCIATION reserves the right to remove from the premises and refuse further admission to any individuals who infringe upon the rights of the **MOVE! NATIONAL DANCE COMPETITION** staff to do their job and/ or who refuse to comply with staff requests to not use video, photographic and cell phone equipment inside the auditorium, create disorder at the venue, engage in disruptive behaviour, show a lack of willingness to comply with basic house rules, use inflammatory speech, make inappropriate personal comments to the organizers and staff, engage in harassment of a physical and/or verbal nature or disrupt others in any way inside the auditorium. Anyone who disrespects any of the above conditions of entry or who does not adopt courteous behaviour will be asked to leave the venue.

